

## The Role of Thin Films in Blood Glucose and BioSensors

### Abstract

Diabetes is now a ubiquitous worldwide disease. An important part of treating this disease is continuous monitoring and management of blood glucose level. Blood glucose levels can be monitored either in ex vivo or in vivo configurations. Electrochemical biosensors for glucose play a leading role in this direction. Amperometric enzyme electrodes, based on glucose oxidase (GO<sub>x</sub>) bound to electrode transducers, are used extensively for home monitoring and have been the target of substantial research and development. Most electrochemical glucose biosensors rely on electron transfer from glucose to the electrode via the active site of the enzyme (GO<sub>x</sub>). However, enzymeless thin film biosensors have also been developed. This article provides a brief description of the test mechanisms, a brief history of this technology and summarizes the three generations of thick film and thin film blood glucose biosensors, including those based on nanomaterials. Advanced designs utilizing carbon nanotubes and mesoporous Pt electrodes are also addressed.

### Introduction

[Diabetes](#) is a world-wide public [health](#) problem of epidemic proportion. It is one of the leading causes of death and disability in the world. Diabetes is a group of diseases marked by high glucose levels in the blood, which may arise from defects in insulin production or insulin action. It is found among a cluster of metabolic diseases that includes insulin resistance, metabolic syndrome and type 2 diabetes, which are tied to a global obesity epidemic. In many American communities, up to 40% of children presenting with type 2 diabetes are obese [1]. Thus, the diagnosis and management of diabetes mellitus requires a tight monitoring of blood glucose levels and self monitoring in particular.

Monitoring blood glucose levels is critical for controlling diabetes. The challenge of providing such tight and reliable glycemic control remains the subject of enormous amount of research [2,3]. Blood glucose levels are monitored by a variety of devices in ex vivo or in vivo configurations. The monitoring devices are part of a larger family of [biosensors](#).

*Biosensors are analytical tools for the analysis of bio-material samples to gain an understanding of their bio-composition, structure and function by converting a biological response into an electrical signal. The analytical devices composed of a biological recognition element directly interfaced to a signal transducer which together relate the concentration of an analyte (or group of related analytes) to a measurable response.*

Blood glucose biosensors utilize a subset of this family, namely bioelectrodes and electrochemical biosensors for blood glucose play a leading role in this direction. Amperometric [enzyme](#) electrodes, based on [glucose oxidase](#) (GO<sub>x</sub>) bound to electrode transducers, have thus been the target of substantial research [2,3]. Since Clark and Lyons first proposed the initial concept of glucose enzyme electrodes in 1962 [4] there has been significant activity towards the development of reliable devices for

self monitoring and continuous diabetes control. A variety of approaches have been explored in the operation of glucose enzyme electrodes (i.e., [bioelectrodes](#)). In addition to diabetes control, such devices offer great promise for other important applications, ranging from food analysis to bioprocess monitoring. Additionally, the great importance of glucose has generated an enormous number of publications, the flow of which shows no sign of diminishing. Yet, despite of impressive advances in glucose biosensors, there are still many challenges related to the achievement of clinically accurate tight glycemic monitoring.

### Bioelectrodes

In order to better understand diabetes monitoring and the role of thin films, it will be instructive to briefly review the history of [blood glucose sensors](#) and how bioelectrodes function. Figure 1 shows the basic elements of a blood glucose sensor and Figure 2 shows working principles of a biosensor. We will be primarily interested in the bio reaction and the electrodes used in the test strip.

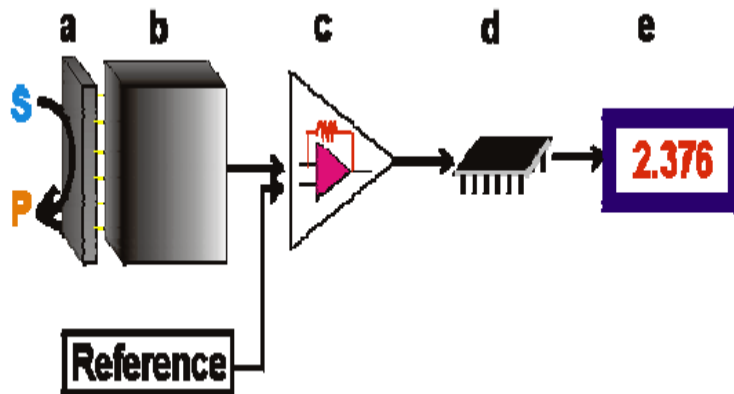

Figure 1. Main components of a biosensor, showing (a) the bio reaction, (b) transducer, (c) processor, (d) amplifier and (e) display.

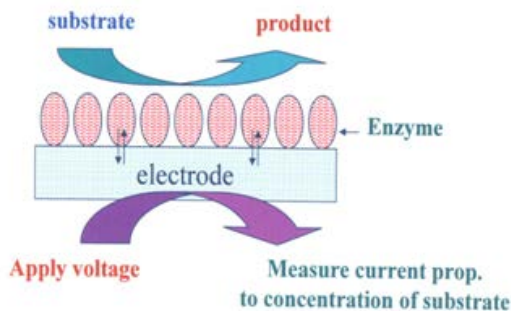

Figure 2. Working principles of a biosensor [5].

The critical mechanism of the biosensor, and one that has experienced the most attention, is *improved transfer of electrons between the GOx active site and the electrode surface*. The first glucose enzyme electrode relied on a thin layer of the enzyme GO<sub>x</sub> (glucose oxidase) entrapped over an oxygen electrode via a semipermeable dialysis membrane [4]. Note that the entire field of biosensors can trace its origin to this original glucose enzyme electrode (see Figure 3), the first bioelectrode. Measurements were made based on the monitoring of the oxygen consumed by the enzyme catalyzed reaction:

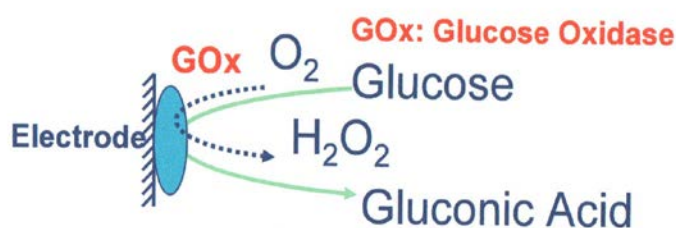

Figure 3. Schematic of electrochemical glucose sensor [5]

A negative potential was applied to a platinum (Pt) cathode for reductive detection of the oxygen consumption:  $\text{O}_2 + 4\text{H}^+ + 4\text{e}^- \rightarrow 2\text{H}_2\text{O}$

This biosensor offered good accuracy and precision but required a blood sample size of 100  $\mu\text{L}$ . Following this initial work, a wide range of [amperometric enzyme electrodes](#) differing in electrode design or material, immobilization approach, or membrane composition were developed [2]. The technology advanced by using electron acceptors to replace oxygen in GO<sub>x</sub>-based blood glucose measurements [6]. Continuous ex-vivo monitoring of blood glucose was demonstrated in 1982 [7,8].

Second generation glucose biosensors used commercial screen printed strips for self-monitoring [9-13]. Modified electrodes and tailored membranes/coatings were developed to enhance sensor performance [14]. In the 1990s, electrical communication between the redox center of GO<sub>x</sub> and the electrode surface was established, including the use of flexible polymer with osmium redox sites [15-19]. Minimally invasive subcutaneously implantable devices were also developed [20-25].

It is also possible to use glucose dehydrogenase (GDH) instead of GO<sub>x</sub> for amperometric biosensing of glucose. However, the construction of glucose biosensors based on GDH requires a source of NAD<sup>+</sup> and a redox mediator to lower the overvoltage for oxidation of the NADH product. Quinoprotein GDH can also be used in connection to a pyrroloquinoline quinone (PQQ) cofactor:

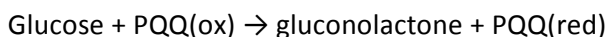

While eliminating the need for a  $\text{NAD}^+$  cofactor, such PQQ enzymes have not been widely used owing to their limited stability.

The following list summarizes the advancement of blood glucose biosensors, and Figure 4 summarizes three generations based on different mechanisms of electron transfer, including the use of natural secondary substrates, artificial redox mediators, or direct electron transfer:

- **First generation:** First generation glucose biosensors relied on the use of the natural oxygen cosubstrate, generation and detection of hydrogen peroxide. Electrons are transferred from glucose to the electrode via the active site of the enzyme (see Figure 3).
  - The biocatalytic reaction involves reduction of the flavin group (FAD) in the enzyme by reaction with glucose to give the reduced form of the enzyme ( $\text{FADH}_2$ ):



Followed by reoxidation of the flavin by molecular oxygen to regenerate the oxidized form of the enzyme  $\text{GO}_x(\text{FAD})$

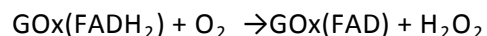

- Measurements of peroxide formation are best made using miniaturized devices which are commonly carried out on a Pt electrode at a moderate anodic potential of around + 0.6 V (vs Ag/AgCl reference). A YSI probe is most often used, which involves the entrapment of  $\text{GO}_x$  between an inner antiinterference cellulose acetate membrane and an outer diffusion limiting/biocompatible one.
- **Second generation:** Further improvements were achieved by replacing the oxygen with a nonphysiological (synthetic) electron acceptor capable of shuttling electrons from the redox center of the enzyme to the surface of the electrode. This improved transfer of electrons between the  $\text{GO}_x$  active site and the electrode surface, which the limiting factor in the operation of first generation amperometric glucose biosensors.
    - Enzyme wiring with a redox polymer offered additional improvements in the electrical contact between the redox center of  $\text{GO}_x$  and electrode surfaces, as shown in Figures 2 and 3. An elegant nondiffusional route for establishing a communication link between  $\text{GO}_x$  and electrodes was accomplished by ‘wiring’ the enzyme to the surface with a long flexible hydrophilic polymer backbone [poly(vinylpyridine) or poly(vinylimidazole)] having a dense array of covalently linked osmium-complex electron relays.
  - **Third generation:** It is desirable to eliminate the mediator and develop a reagentless glucose biosensor with a low operating potential, close to that of the redox potential of the enzyme. In this case, the electron would be transferred directly from glucose to the electrode via the active

site of the enzyme. The absence of mediators is the main advantage of third generation biosensors, leading to a very high selectivity (owing to the very low operating potential).

However, acritical challenges must be overcome for the successful realization of this direct electron transfer route owing to the spatial separation of the donor-acceptor pair. Efficient direct electron transfer at conventional electrodes has been reported only for few redox enzymes. We will address these biosensors in more detail later in this article.

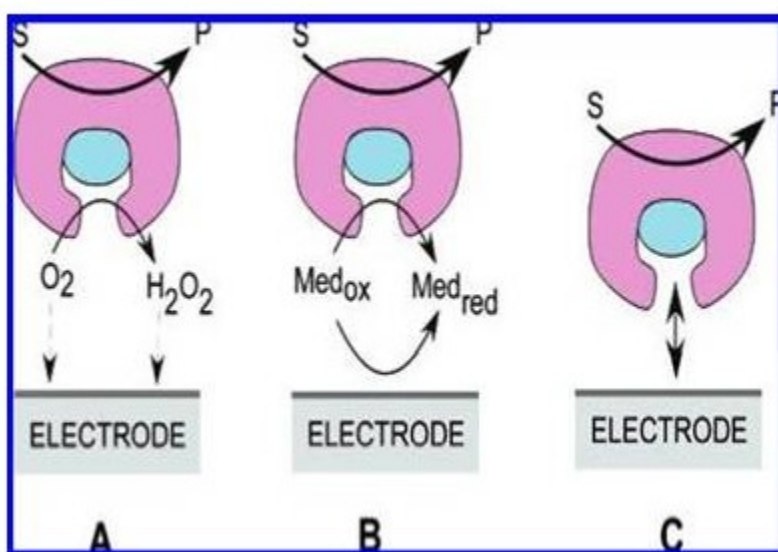

Figure 4. Three generations of amperometric enzyme electrodes for glucose based on the use of natural oxygen cofactor (A), artificial redox mediators (B), or direct electron transfer between GOx and the electrode (C).

### Glucose Sensor Technologies

With this brief review in mind, we now address current glucose biosensor technologies and the role of thin films. These devices are based on thick and thin film technologies, but we focus on thin films. The most wide used technologies for self monitoring glucose blood (SMBG) testing are [5]

- **Electrochemical:** Potentiometric devices (ISE and ISFET), amperometric devices (electrode), conductometric devices (chemiresistor and BLM)
  - Changes in voltage, current, impedance and/or resistance
  - Includes thin and thick film electrodes

- Optical: Fiber optic and planar devices utilizing absorption, scatter, polarization, reflectivity and interference of light
  - Changes in wavelength, intensity, emission profile, reflectivity, fringe patterns, polarization state and refractive index

Figure 5 shows the distribution of these technologies as of 2009. Over two thirds of the blood glucose test strip market is based on electrochemical technology (compared to optical). Nearly half of the market is electrochemical, with strips based on thick film electrodes. Roughly 30% of the market is electrochemical, but based on thin-film electrodes produced by vacuum sputtering processes.

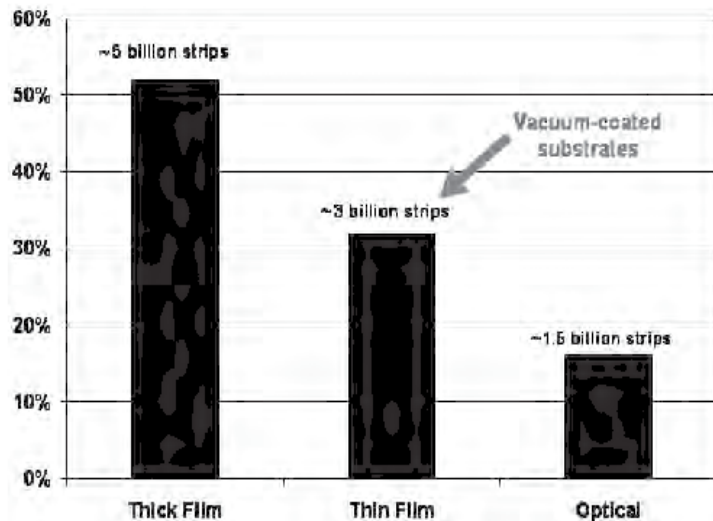

Figure 5. Distribution of blood glucose test strip technologies as of 2009 [26].

Electrochemical biosensors are well suited for addressing the needs of personal (home) glucose testing and have played a key role in the move to a more simple one-step blood sugar testing. Since blood glucose home testing devices are used daily to diagnose potentially life-threatening events, they must be comprised of extremely high quality materials. As shown in Figure 5, the majority of personal blood glucose monitors rely on disposable screen-printed enzyme electrode test strips [26,27,28]. Single use electrode strips are mass produced by the rapid and simple thick film (screen printing) microfabrication or vapor deposition process [29,30]. [Screen printing](#) technology involves printing patterns of conductors and insulators onto the surface of planar solid (plastic or ceramic) substrates based on pressing the corresponding inks through a patterned mask. Each strip contains printed working and reference electrodes (see Figure 6), with the working one coated with the necessary reagents (i.e., enzyme, mediator, stabilizer, surfactant, linking, and binding agents) and membranes (Figures 6 and 7). The reagents are commonly dispensed by ink jet printing technology and deposited in the dry form. A counter electrode and an additional (“baseline”) working electrode may also be included. Various

membranes (mesh, filter) are often incorporated into the test strips and along with surfactants are used to provide a uniform sample coverage and separate the blood cells. Such single-use devices eliminate problems of carry over, cross contamination, or drift. Overall, despite their low cost and mass production such sensor strips are based on a high degree of sophistication essential for ensuring high clinical accuracy.

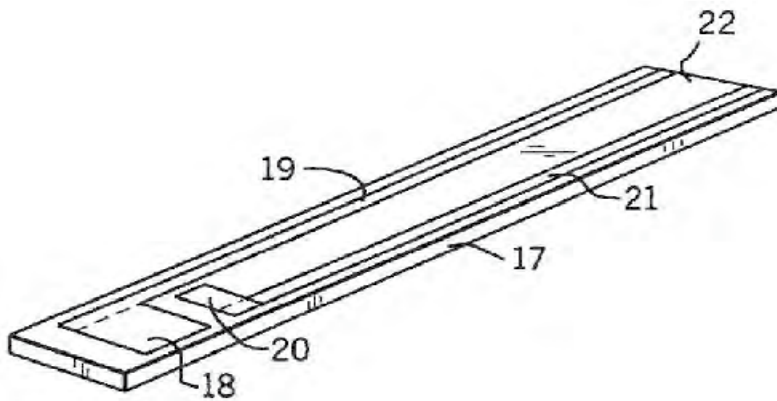

Figure 6. Schematic of thick film blood glucose test strip [26].

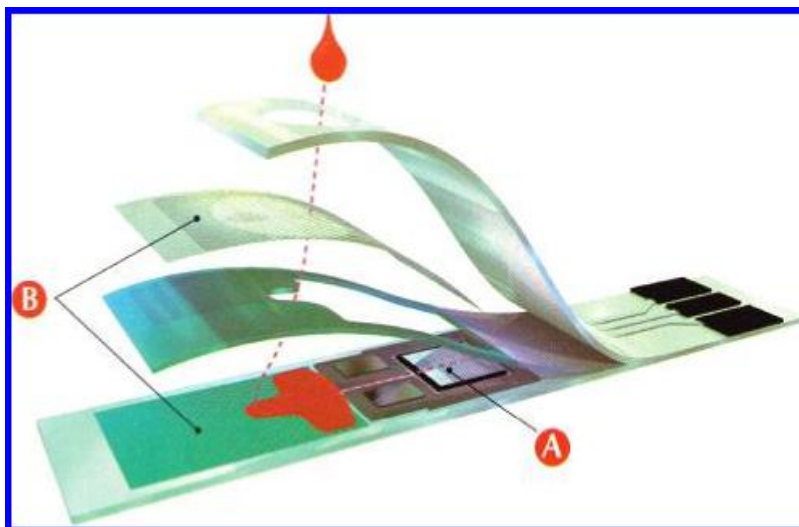

Figure 7. Cross section of a commercial strip for self-testing of blood glucose (based on the Precision biosensor manufactured by Abbott Inc.): (A) electrode system; (B) hydrophobic layer (drawing the blood).

## Fabrication Methods for Thin Film Glucose Test Strips

Figures 7 and 8 shows an example of a test strip based on thin film electrodes [26]. Here noble metals are used as electrodes, and [evaporation](#) processes are used primarily for fabrication of electrodes in test strips [27]. As we see from above, virtually all electrochemical blood glucose sensors employ enzymes because of their high selectivity. However, a major problem with these biosensors is that they are limited for reuse due to the limited lifetime of enzymes, which causes additional expense.

In order to overcome these limitations, mesoporous (pores with a size of 2–50 nm) Pt films formed on a rod shaped Pt microelectrode were reported for glucose detection *without enzymes* [31]. With this type of electrode, the large surface area of the mesoporous Pt significantly enhanced [glucose sensitivity](#).

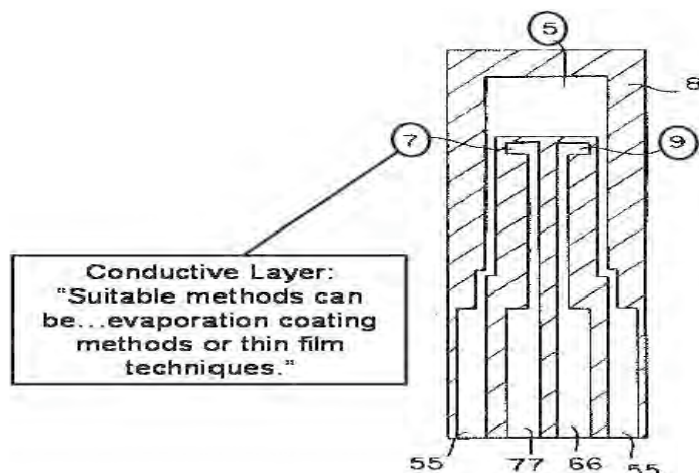

Figure 8. Diagram of thin film Glucose test strip [26,27].

It is also known that the reactivity of ascorbic acid (AA) and acetaminophen (AP) with glucose in human blood, is significantly less than with enzymes since the depth of the diffusion layer is several micrometers in the chronoamperometric diffusion field formed in the electrochemical analysis [29]. The response current of mesoporous Pt electrodes is large enough to be used as a working electrode without any enzymes (e.g. GOx) because rapidly oxidizable and reducible reactants such as AA and AP are readily dissipated in the diffusion layer and slowly reacted reactants (glucose) are distributed and reacted along with the surface of the mesoporous Pt electrode. The properties of the mesoporous Pt electrodes were first studied in 1997 [30].

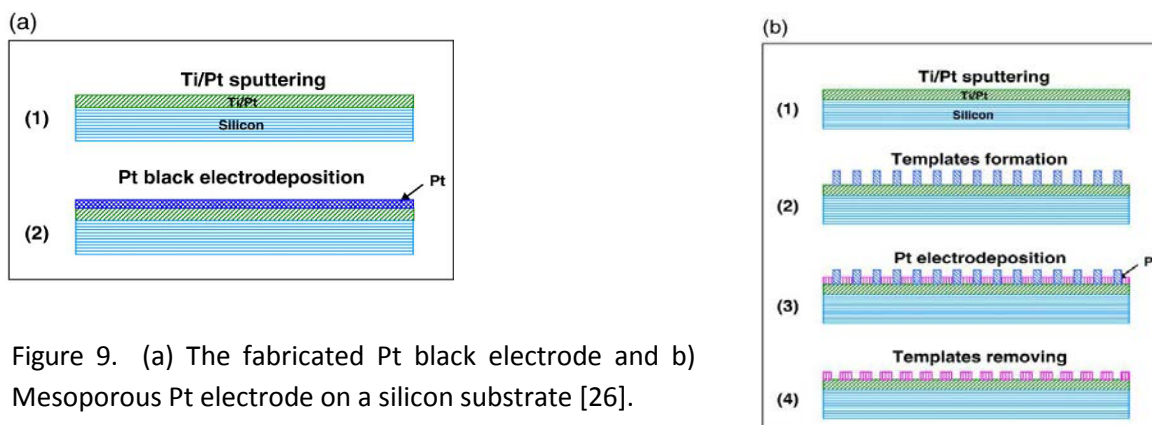

Figure 9. (a) The fabricated Pt black electrode and b) Mesoporous Pt electrode on a silicon substrate [26].



Referring to Figure 9a, the planar Pt electrode was deposited by [sputtering](#) Ti and Pt films on high resistivity silicon wafers. A Pt black electrode and the mesoporous Pt electrode were then applied over the plane Pt electrode. Fabrication steps for this electrode were reported earlier [32]. The Pt black electrode is a fine powder of with good catalytic properties. The name of [platinum black](#) is due to its black color is generally deposited by electrodeposition [32]. A typical black Pt deposit is shown in Figure 10. Figure 9a shows the fabrication steps for the sputtered Ti/Pt films and the Pt black electrode. The Pt black electrode was fabricated by electrodeposition of platinum ions on the sputtered Pt electrode from a 50% HCPA (hexachloroplatinic acid hydrate) aqueous solution, and applying constant potential at  $-0.12$  V vs. Ag/AgCl reference.

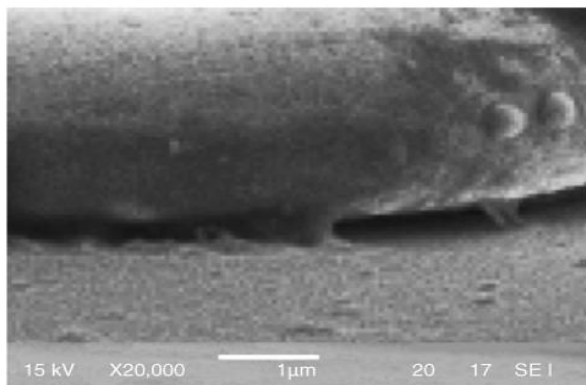

Figure 10. SEM of Pt black [30].

Figure 9b shows the fabrication steps for the full [mesoporous](#) Pt electrode. The mesoporous Pt electrode with approximately 3 nm pore diameter was electrodeposited over the sputtered Pt layer, patterned with a nonionic surfactant octaethylene glycol monohexadecyl ether ( $C_{16}EO_8$ ) and HCPA. Liquid crystal templates with hexagonally arrayed pillars were prepared at  $25$  °C, Pt was electrodeposited by applying constant potential at  $-0.12$  V vs. Ag/AgCl (reference). In this step, the thickness of mesoporous Pt was equal to that of the Pt black electrode. After electrodeposition, the surfactant templates were fully removed in deionized water by soaking and rinsing.

The performance of the two electrodes was compared. As demonstrated in Figures 11 and 12, the mesoporous Pt electrode was found to be more sensitive than the Pt black electrode for slowly reacted reactants (e.g. glucose). The response current of the mesoporous Pt electrode, shown in Figure 11, was similar to that of the Pt black electrode in rapidly oxidizable and reducible reactants (e.g. hydrogen peroxide and sulfuric acid), but is significantly better than that of the Pt black electrode in slowly reacted reactants (e.g. glucose), which indicated that the mesoporous Pt electrode was much more sensitive than the Pt black electrode in glucose solution. Additionally, nanopores of the mesoporous Pt electrode increased effectiveness for the analysis of glucose.

[Chronoamperometry](#) was performed at various glucose concentrations to verify blood glucose sensing of the electrodes. Figure 12 shows amperometric responses of the Pt electrodes at various glucose concentrations at an applied voltage 0.4 V vs. Ag/AgCl reference at various concentrations of glucose for exposures of 6 s. Amperometric response was found to increase linearly with glucose concentration for both electrodes. Thus, mesoporous Pt electrodes were found to be promising for the development of enzymeless electrochemical sensors. These results also suggested that the mesoporous Pt electrode is useful for micro-batteries, micro-fuel cells, and other electrochemical sensor applications. In particular, the mesoporous Pt electrode has great potential for use in chemical, environmental, and biological analysis systems.

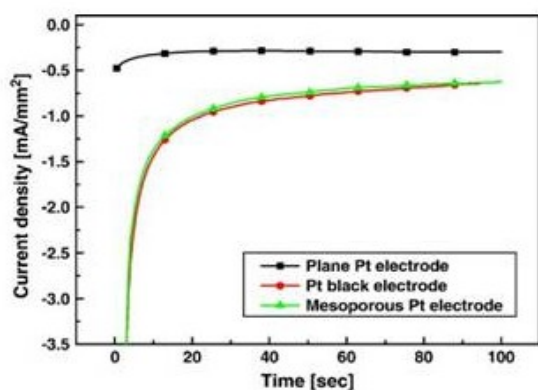

Figure 11. Comparison of chronoamperometric responses of Pt electrodes in 10 mM glucose with 0.1 M PBS solution at an applied voltage

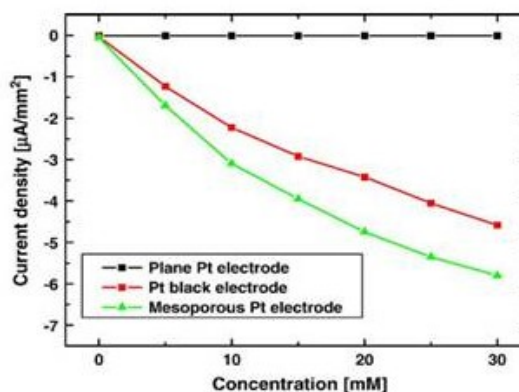

Figure 12. Comparison of amperometric responses of Pt electrodes to the successive addition of 10 mM glucose with 0.1 M PBS solution at an applied voltage 0.4 V [28].

### The Future of Thin Films in Blood Glucose Biosensors

#### Nanotechnology

The emergence of [nanotechnology](#) has opened new horizons for the application of nanomaterials in bioanalytical chemistry. Recent advances in nanotechnology offer exciting prospects in the field of bioelectronics. One of the main problems with glucose biosensors is efficient electron transfer from glucose to the electrode via the active site of the enzyme. [Carbon nanotubes](#) (CNT) can have almost perfect electrical conduction properties and are being developed for a wide range of microelectronic and sensor applications, including biosensors [33]. Functionalized graphene (e.g., single wall carbon nanotubes: SWCNT) is now being developed for use in glucose biosensors [34]. Owing to the similar dimensions of nanoparticles and redox proteins nanoparticles and nanomaterials can be used for effective electrical wiring of redox enzymes. Various nanomaterials, including gold nanoparticles or CNT, have thus been used as electrical connectors between the electrode and the redox center of GOx. For example, apo-glucose oxidase can be reconstituted on a 1.4 nm gold nanocrystal functionalized with the FAD cofactor [35]. A Au nanoparticle, can be immobilized onto a Au electrode by means of a dithiol

linker, and will act as an “electrical nanoplug” (relay unit) for the electrical wiring of its redox-active center. This leads to a high electron transfer turnover rate of  $\sim 5000/s$ .

Additionally, CNT can be coupled to enzymes to provide a favorable surface orientation and act as an electrical connector between their redox center and the electrode surface. Particularly useful for this application have been vertically aligned CNTs that act as molecular wires (‘nanoconnectors’) between the underlying electrode and a redox enzyme [36-38]. Figure 13 shows how aligned reconstituted GOx on the edge of SWCNT’s can be linked to an electrode surface [36]. Such enzyme reconstitution on the end of CNT represents an extremely efficient approach for ‘plugging’ an electrode into GOx. Electrons are transported along distances greater than 150 nm, with the length of the SWCNT controlling the rate of electron transport. An interfacial electron transfer rate constant of 42/s was estimated for 50 nm long SWCNT. At present, activation of the bioelectrocatalytic functions of GOx by nanoparticles or CNT requires electrical over potentials (beyond the thermodynamic redox potential of the enzyme redox center). Improving contact between the nanomaterial and the electrode might decrease this over potential.

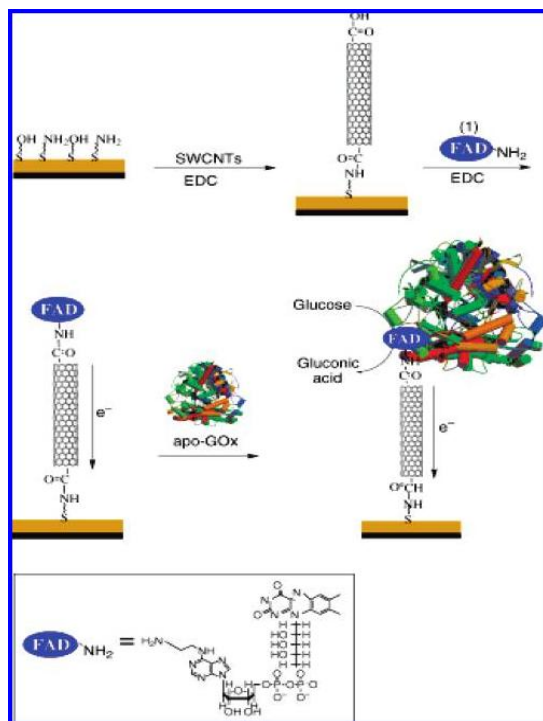

Figure 13. assembly of the CNT electrically contacted GOx electrode [34].

The ultimate goal of this technology is to eliminate the mediator and develop a reagentless (and possibly an enzymeless) glucose biosensor with a low operating potential, close to that of the redox potential of the enzyme. Here, the electron is transferred directly from glucose to the electrode via the active site of the enzyme. The absence of mediators is the main advantage of third-generation biosensors, leading to a very high selectivity (owing to the very low operating potential). However, critical challenges must be overcome for the successful realization of this direct electron transfer route owing to the spatial separation of the donor acceptor pair. Efficient direct electron transfer at conventional electrodes has been reported only for few redox enzymes. To this end, new electrode materials are being developed to obtain direct electron transfer of GOx. An optimally designed electrode configuration must ensure that the electron transfer distance between the immobilized protein and the surface is made as short as possible.

Referring back to Figure 4 which summarizes the three generations of amperometric glucose biosensors based on different mechanisms of electron transfer, including the use of natural secondary substrates, artificial redox mediators, or direct electron transfer, third generation glucose sensors are shown on the right of the Figure. Although substantial progress has been made on the electronic coupling of GOx, further improvements in the charge transport between its FAD redox center and electrodes are needed [39].

One technique for creating third generation amperometric glucose biosensors is to use conducting organic salt electrodes based on charge transfer complexes such as [tetrathiafulvalene-tetracyanoquinodimethane](#) (TTF-TCNQ) [40-42]. Different electron transfer mechanisms at TTF-TCNQ electrodes have been proposed, and the precise mechanism of GOx catalysis remains controversial [39]. For example, one such mechanism is based on a stable charge transfer complex electrode [41].

The device relies on the growing tree shaped crystal structure of TTF-TCNQ. The close proximity and favorable orientation of the enzyme at the crystal surface apparently allows direct oxidation of the enzyme and selective glucose measurements at 0.1 V (vs Ag/AgCl reference), although they did not provide a convincing evidence for such direct electron transfer. A number of other devices have been proposed as third generation blood glucose biosensors [42 – 46], and will not be described here.

### The Market

The explosive growth of diabetes is the primary driver for the increase in revenue for products that enable self management of the disease. Global figures and estimates for self [monitoring of blood glucose](#) (SMBG) product revenue show an increase that outpaces the increase in diagnosed diabetes cases alone, as shown in Table 1. Self testing has increased significantly, which drives the market for self monitoring blood glucose products [47,48]. Studies clearly indicate that SMBG is the most important factor in achieving glycemic control. The ability to monitor one's blood glucose at home (or other locations outside of a clinical laboratory) has been described as a recent "miracle" in diabetes treatment [49].

Table 1: Worldwide market for SMBG products.

Year	Global Revenue, \$billion
1998	2.7
2005	7.0
2009	10.0
2012	12.0

### SMBG TEST STRIP MARKET

Today's technology for self monitoring of blood glucose has taken nearly 50 years passed through three generations and is now involving microstructures. Self monitoring involves miniature devices with test strips. Amperometric enzyme electrodes, based on glucose oxidase ( $GO_x$ ) bound to electrode transducers, are used extensively for home monitoring. Most electrochemical glucose biosensors rely on electron transfer from glucose to the electrode via the active site of the enzyme ( $GO_x$ ). However, enzymeless thin film biosensors have also been developed. Early test strips required up to 50  $\mu$ L of blood and developed a change in color in response to the presence of glucose. Electrochemical systems own the majority of today's market, and utilize sample sizes well less than 1  $\mu$ L. Electrochemical SMBG tests strips are primarily based on thick film technology but thin films also corner part of this market. Advanced designs utilize carbon nanotubes and mesoporous Pt electrodes. Since SMBG system manufacturers have significant resource and regulatory hurdles to surmount, suppliers of thin film based products need to convince test strip manufacturers that vacuum coated flexible substrates reduce cost and process complexity while providing product performance advantages.

[Materion](#) offers a number of products and services applicable to fabrication of blood glucose test strips. A wide range of source materials is available for [evaporation and sputtering processes](#). Materion also offers [Technical Services](#) to support your deposition and materials problems

### Additional Reading:

1. <http://www.diabetes.org/diabetes-basics/?loc=GlobalNavDB>
2. Francois Leonard, The Physics of Carbon Nanotube Devices, William Andrew (2009)
3. Handbook of Deposition Technologies for Films and Coatings, Third Ed., Peter M Martin (Editor), Elsevier (2009).
4. Jerome McAleer, David Scott, Geoff Hall, Manuel Alva-rez-Icaza, Elliott Plotkin and Oliver Davies, US Patent #7,112,265, "Disposable Test Strips with Integrated Reagent/Blood Separation Layer," Sep. 26, 2006.
5. Joachim Hoenes and Jurgen Schaeffler, US Patent #5,122,244, "Method and Sensor Electrode System fort the Electrochemical Determination of an Analyte or an Oxidoreductase As Well As the Use of Suitable Compounds Therefor," June 16, 1992.

6. C Oehr, Biomedical Applications of Thin Films Deposited by Plasma Polymerization, SVC 49th Annual Technical Conference Proceedings (2006) 105.

### Reference:

1. Therapy of Diabetes Mellitus and Related disorders, 4th ed., edited by Harold E. Lebovitz, pp. 1-7, American Diabetes Association, 2004.
2. G Reach & G S Wilson, Anal Chem 64 (1992) 381A.
3. A P Turner et al., B. Chen, S. Piletsky, Clin. Chem. 1999, 45, 1596.
4. L Clark Jr. & C Lyons, Ann NY Acad Sci 29 (1962) 102.
5. Li Chenzhong, Introduction and Overview to Biosensors and Electrochemistry, Lecture 1: Nanobioengineering&Bioelectronics Lab, Department of Biomedical Engineering, Florida International University, [licz@fiu.edu](mailto:licz@fiu.edu).
6. P Schlapfer et al., Clin Chim Acta 57 (1974) 283.
7. A Albisser et al., Diabetes 23 (1974) 397.
8. M Shichiri et al., Lancet 2 (1982) 1129.
9. A Cass et al., Anal Chem 56 (1984) 667.
10. H A O Hill, Eur Pat Appl EPO 125,139 A2, 14, 45-46, 1984.
11. J Frew & H A Hill, Anal Chem 59 (1987) 933A.
12. P Hilditch & M Green, Analyst 116 (1991) 1217.
13. D Matthews et al., Lancet 2 (1987) 778.
14. R Murray et al., Anal Chem 59 (1987), 59, 379A.
15. Y Degani & A Heller, J Phys Chem (1987) 1285.
16. T Ohara et al., Anal Chem 66 (1994) 2451.
17. I Willner et al., J Am Chem Soc 118 (1996) 10321.
18. Y Xiao et al., Science 299 (2003) 1877.
19. P Bartlett et al., Anal Chem 69 (1997) 734.
20. G Reach & G S Wilson, Anal Chem 64 (1992) 381A.
21. P N Bartlett et al., Anal Chem 69 (1997) 734.
22. D Bindra et al., Anal Chem 63 (1991) 1692.
23. E Csoregi et al., Anal Chem 67 (1995) 1240.
24. Henry, C. Anal. Chem. 1998, 70, 594A.
25. D Schmidtke et al., Proc Natl Acad Sci USA 95 (1998) 294.
26. D Brown, SVC 53<sup>rd</sup> Annual Technical Conference Proceedings (2010) 160.
27. Joachim Hoenes and Jurgen Schaeffler, US Patent #5,122,244, "Method and Sensor Electrode System for the Electrochemical Determination of an Analyte or an Oxidoreductase As Well As the Use of Suitable Compounds Therefor," June 16, 1992.
28. S J Park et al., Talanta Chem 75 (2003) 3046.
29. S Park et al., Anal Chim Acta 556 (2006) 46.

30. G.S. Attard, P.N. Bartlett, N.R.B. Coleman, J.M. Elliott, J.R. Owen, J.H. Wang, *Science* 278 (1997) 838.
31. Hye-Kyoung Seo et. al., *Thin Solid Films* 516 (2008) 5227.
32. A Kicela & S Daniele, *Talanta* 68 (2006) 1632.
33. P M Martin, *Introduction to Surface Engineering and Functionally Engineered Materials*, Wiley/Scriviner (2011).
34. Dan Zheng et al., *Talanta* 99 (2012) 22.
35. Y Xiao et al., *Science* 299 (2003) 1877.
36. F Patolsky et al., *Chem Int Ed* 43 (2004) 2113.
37. J Q Liu et al., *Electroanalysis* 17 (2005) 38.
38. J J Gooding et al., *J Am Chem Soc* 125 (2003) 9006.
39. Joseph Wang, *Chem Rev* 108 (2008) 814□
40. W Albery et al., *J Electroanal Chem* 194 (1985) 223.
41. G F Khan et al., *Anal Chem* 68 (1996) 2939.
42. F Palmisano et al., *Anal.Chem* 74 (2002) 5913.
43. N K Cenas et al., *J.Bioelectrochem.Bioenerg* 8 (1981) 103.
44. S Yabuki et al., *J Chem Soc, Chem Commun* (1989) 945.
45. C G Koopal et al., *J Chem Soc, Chem Commun* (1991) 1691.
46. W Jing & Q Wang, *Anal Bioanal Chem* 385 (2006) 1330.
47. Diabetes Control and Complications Trial Research Group, "The effect of intensive treatment of diabetes on the development and progression of long-term complications in insulin-dependent diabetes mellitus," *N Engl J Med* 329(14) (1993) 977.
48. United Kingdom Prospective Diabetes Study Group, "Intensive blood-glucose control with sulfonylureas or insulin compared with conventional treatment and risk of complications in patients with type 2 diabetes," *Lancet* 352 (1998) 837.
49. Diabetes for Diabetics, A Practical Guide, George Schmitt, The Diabetes Press of America, (1965) 3.
50. IMS Health, 2009.