

Surface Coating of Copper Alloy Strip for Electrical Connector Applications

In order for electrical contacts to function properly, it is necessary to keep the total resistance of the contact interface low. This requires smooth contact surfaces, adequate normal force, good wear resistance of the contact surfaces, good electrical conductivity, and absence of corrosion products. These factors can be adjusted coating the surfaces of the terminal. Each coating type will contribute some combination of these critical properties to the interface. The choice of a correct coating can mean the difference between a good electrical contact (signal transmission) and a failed connection.

COATING METHODS

There are several methods that are used to apply materials to connector interfaces. These methods include electro- and electroless plating, cladding, hot dipping, reflowing, and vapor deposition.

In **electroplating**, the metal strip is immersed in an electrolytic solution while connected to the negative end of a DC terminal. The positive end is connected to pieces of the desired plating metal immersed in the same solution. The action of the electric current in this electrolytic cell causes the contact metal to dissolve and plate out onto the surface of the strip.

Hot dipping involves passing the metal strip through a molten version of the desired coating material, enabling it to adhere to the strip and solidify on it.

For **overlay cladding**, a strip of the coating material is rolled onto the base metal strip, and the two are sintered together. This creates a metallurgical bond between the two surfaces. In **inlay cladding**, a small section of the base metal strip is skived out or milled out along its length. A strip of the coating material is then rolled into place in the newly exposed groove, and the two pieces are then rolled together and sintered. Multiple layered clads can be added to the base metal, and thick coatings can be created quickly and easily.

Electroplating

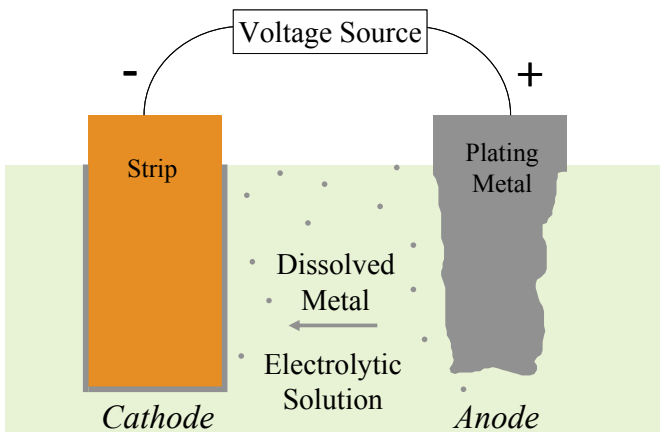

Electroless plating differs from electroplating in that it is not activated by an applied electric current. It employs a solution containing dissolved ions of the plating metal. The base metal of the strip catalyzes the reaction that plates the ions onto its surface.

Skive Inlay Technique

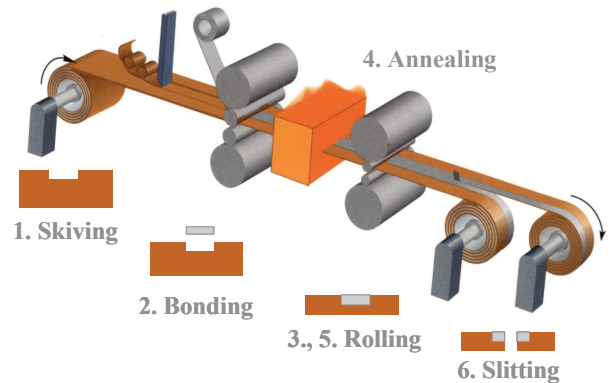

Solder print-on involves moving the strip over counter-rotating rollers partially immersed in liquid solder. This prints solder onto the strip in much the same way as a printing press placing ink on paper.

Alternatively, a strip of solid solder may be laid on the base metal (by plating, cladding, ect.) and then briefly melted and resolidified for adhesion to the surface. This is known as **reflowing**. Reflowing of a solder coating, particularly one that is electroplated, will eliminate the residual stresses that lead to the formation of tin whiskers.

In **physical vapor deposition**, or PVD the plating material is evaporated in a low pressure environment by electrical arcing or by a focused electron beam (sputtering). The vapor condenses on the base metal and slowly coats it.

CLEANING

All surfaces should be clean and free of grease and oxide before the surface can be coated. BeCu strip may be degreased with an alkaline cleaner. It may then be cleaned using one of the following solutions: sulfuric peroxide (20% H₂SO₄, 3% H₂O₂) at 125 F, or Phosphoric/Nitric/Acetic (38% H₃PO₄, 2% HNO₃, 60% acetic acid) at 160°F. Alternatively, the strip may be pretreated with caustic (50-60% NaOH) at 265°F, then pickled in Nitric acid. For further information on cleaning and oxide removal, refer to the "Cleaning Copper Beryllium" Tech Brief.

NICKEL UNDERPLATING

In order for a coating to work properly, it must prevent the base metal from coming into contact with the outside environment. However, the base metal may slowly diffuse through the coating and combine with oxygen to form an oxide on the surface. For this reason, an undercoat of nickel is usually placed between the base metal and the outer coating. The nickel acts as a diffusion barrier that inhibits the migration of copper atoms to the contact surface. Additionally, it functions as a thermal barrier to prevent the heat from surface soldering from affecting the base metal.

Without an underplate, pores in the plating may leave BeCu exposed to the outside air. This will allow copper oxide corrosion products to form in the pores and migrate to the surface. By using an underplate, nickel oxide will form in the pores instead. Since the corrosion rate of NiO is very slow under stable conditions, once the underlying Ni is covered, the corrosion products do not migrate and the pores are essentially passivated. This will also slow the migration of corrosion products from bare edges of the contact.

A nickel underplate will also increase the wear resistance of

the contact, especially when the overplate is gold.

MULTI-LAYER COATINGS

There are some instances when it is desirable to use coatings consisting of multiple layers. **Capping** involves placing a thinner layer of one coating on top of another one, as in gold over a nickel underplate. A **flash** coating is a very thin overcoat, generally used to improve the corrosion resistance of the surface. **Diffusion** involves heating the material, so atoms of the top coating diffuse down into the lower layers.

RESIDUAL AND INDUCED STRESSES

Coatings applied by electroplating, vapor deposition, and electroless plating will contain a certain amount of internal residual stress. This stress is created as the coating grows in thickness. Additionally, thermal expansion differences between the coating and the substrate will create thermal stresses, especially if the coating is deposited at high temperatures and then cooled. (The thermal stresses will also cycle with temperature during normal service of the part.) Residual tensile stresses may lead to premature fatigue failure, while residual compressive stresses can improve resistance to this type of failure. Excessive tensile stress in the coating may also cause cracking.

PREPLATING VS. POSTPLATING

Mill hardened strip may be plated before or after stamping and forming operations. Heat treatable strip must be plated after heat treatment, to prevent diffusion of the base metal into and through the plating material.

Preplating or precladding will leave the base metal exposed at edges of the part after stamping. Corrosion can occur at these bare edges. This can allow corrosion products to creep across the surface of the contact, disrupting the flow of current. Preplating will also produce stamping scrap that has been coated with the plating material. It can be difficult to recover plating metal from this scrap. Depending on the thickness and ductility of the coating, the formability of the part may be substantially reduced, since a less ductile coating will fracture more easily than the base metal.

Postplating requires that the part be stamped, and then coated selectively or overall. However, the edges of the part will be coated. If the part is to be spot plated, it must be blanked, spot plated, and then formed. This requires that the stamping and forming operations be done at separate times, with an intermediate coating operation.

Materion Brush Performance Alloys

6070 Parkland Boulevard
Mayfield Heights, OH 44114 USA
phone: 216.486.4200 fax: 216.383.4005
e: BrushAlloys-Info@Materion.com

TECHNICAL INQUIRIES

ph: 800.375.4205

MATERION CORPORATION

www.materion.com

AT0017/0311

©2011 Materion Brush Inc.

It should also be noted that certain plating materials are available only as preplated, and others only as postplated. Cladding is only done before stamping.

Materion Brush Performance Alloys supplies strip in both the bare and preplated conditions.

COATING MATERIALS

Gold (Au) is the most inert of all of the plating materials. It does not readily tarnish or stain. Soft (pure) gold is not durable, and is only suitable for light contact force. Hard gold (with added cobalt or nickel) provides added durability. Gold is usually applied over a nickel undercoat. However, it may also be applied as a flash coating over another, cheaper contact material. Gold is not easily soldered, and should not be mated against tin.

Silver (Ag) has very high electrical conductivity, but is prone to tarnishing in the presence of chlorine or sulfur. Silver is fairly resistant to arcing damage, and is often used in high current applications.

Platinum (Pt) and **Palladium (Pd)** are similar to gold in that they do not readily tarnish, and do require a nickel underplate. They are harder and more durable than gold. In the presence of organic compounds, they may form a powdery film. Often, they will be topped by a gold flash to prevent this film from forming.

Nickel (Ni) is typically used as an underplate for the reasons outline above. A nickel underplate also prevents the formation of a brittle copper-tin intermetallic phase in tin-based coatings. If used as a standalone coating, it requires very high normal force (greater than 200 grams) and wiping action during contact mating, with a minimum of 12 Volts to frit through the nickel oxide layer on the surface. Nickel platings can have high residual stresses, particularly when brightening agents are present in the plating bath. These stresses may negatively affect formability and fatigue life. Post-plating heat treatments can be applied to harden the plating or reduce the residual stresses.

Tin (Sn) is a very low cost, solderable material. It is prone to fretting corrosion, so the interface should be lubricated and mated with sufficient normal force (typically greater than 100 grams) and wiping action during the connector mating process. Unless they are reflowed, tin platings have a tendency to produce tin whiskers, which may lead to short circuits or other problems electrical problems. Tin has a

tendency to form a brittle intermetallic phase when applied directly on copper alloys, so a nickel underplate is recommended. Tin coated contacts should not be mated to gold.

Tin-Lead (Sn-PB) Solders are used on interfaces that need to be solderable. The lead content helps to prevent the formation of tin whiskers. However, these alloys are no longer permitted under the European RoHS regulations.

A number of **Lead-Free (Pb-Free) Solders** are now available to replace tin-lead solders in electronic applications. These are primarily made of various combinations of tin, silver, copper, bismuth, zinc, and indium. They do have higher reflowing temperatures than tin-lead solders, so electronic components have to be carefully designed to ensure that they are not damaged by the higher processing temperatures.

READING THE ACCOMPANYING CHART

The chart on the next two pages details some common coatings and their application methods. The common reasons for use and drawbacks are listed. The surface hardness values are tabulated, along with electrical conductivity in % IACS (Pure copper has 100% IACS.) The typical current and voltage used with each coating is listed (except for the solders, which are used for permanent bonding, and not for contact). Recommendations are given for minimum normal force requirements, and for the maximum operating temperature. Please note that this chart serves as a general guide only. The normal force requirements are also dictated by the severity of the environment and smoothness of the surfaces. Some applications may function properly at greater temperatures and voltages than those specified on the chart.

MATERION TECHNICAL MATERIALS

Materion Technical Materials is a Materion company that specializes in coating technology. They have the capabilities to inlay and overlay clad metals in single or multiple layers. Many precious and nonprecious metals can be clad, including solders. TMI also has the capability to electroplate overall or selective stripes of hard Au, Pd, PdNi, Ni, Sn, and SnPb solders. They are also able to spot plate hard and soft Au, Pd, PdNi, Ni, Sn, and SnPb solders on previously stamped strip. Materion Technical Materials may be reached at 1-800-241-2523.

Materion Brush Performance Alloys

6070 Parkland Boulevard
Mayfield Heights, OH 44114 USA
phone: 216.486.4200 fax: 216.383.4005
e: BrushAlloys-Info@Materion.com

TECHNICAL INQUIRIES

ph: 800.375.4205

MATERION CORPORATION

www.materion.com

AT0017/0311

©2011 Materion Brush Inc.

SAFE HANDLING OF COPPER BERYLLIUM

Please refer to the Materion Corporation publications “Safety Facts 104 - Safety Practices for the Chemical Processing of Small Copper Beryllium Alloy Parts”, and “Safety Facts 105 - Processing Copper Beryllium Alloys.”

Handling copper beryllium in solid form poses no special health risk. Like many industrial materials, beryllium-containing materials may pose a health risk if recommended safe handling practices are not followed. Inhalation of airborne beryllium may cause a serious lung disorder in susceptible individuals. The Occupational Safety and Health Administration (OSHA) has set mandatory limits on occupational respiratory exposures. Read and follow the guidance in the Material Safety Data

Sheet (MSDS) before working with this material. For additional information on safe handling practices or technical data on copper beryllium, contact Materion Brush Performance Alloys, Technical Service Department at 1-800-375-4205.

FOR MORE INFORMATION

For additional literature, further information, or technical assistance on alloy properties or processing of high performance alloy strip, contact Materion Brush Performance Alloys Customer Technical Service Department in Mayfield Heights, Ohio at 1-800-375-4205. For more information on platings, claddings, and other methods of application, contact Materion Technical Materials at 1-800-241-2523.

Materion Brush Performance Alloys

6070 Parkland Boulevard
Mayfield Heights, OH 44114 USA
phone: 216.486.4200 fax: 216.383.4005
e: BrushAlloys-Info@Materion.com

TECHNICAL INQUIRIES

ph: 800.375.4205

MATERION CORPORATION

www.materion.com

AT0017/0311

©2011 Materion Brush Inc.

Surface Coatings for High Performance Copper Alloy Strip

Alloy	Uses and Advantages	Susceptibilities	Application Methods	Normal Force Requirements	Hardness	Maximum Service Temperature	Electrical Conductivity % IACS
Soft Gold (Au)	Wire bonding to gold wires Noble, forms no films	Wears quickly, good for very light loads only	electroplating cladding PVD electroless	< 20 grams	< 75 HV	200°C	73
Hard Gold (96 Au 4 Ni/Co) 75 Au 25 Ag	Noble, forms no films. Increased wear resistance over soft gold Less expensive than gold, higher conductivity	Not easily solderable, high cost Forms sulfides	electroplating cladding cladding	> 25 g > 50 g	150 - 210 HV 50 - 110 HV	125°C 125°C	73 17
69 Au 25 Ag 6 Pt	Hardness equivalent to hard Au, but lower density and cost, can be used to cap other coatings	May form small amounts of film on surface	cladding	> 50 g	80 - 140 HV	300°C	10
Palladium (Pd)	Hardness and wear resistance of gold. Forms no oxides or sulfides	Catalyst - forms organic films, may require Au flash	electroplating cladding electroless cladding	> 50 g	200 - 400 HV	200°C	16
60 Pd 40 Ag	Very hard, requires little normal force	Catalyst - forms organic films, forms sulfides, requires Au flash	cladding	> 100 g	175 - 195 HV	200°C	4
Pd Ni / Pd Co	Higher hardness than PdAg good formability	Catalyst - forms organic films, costs more than PdAg	electroplating cladding	> 50 g	300 - 550 HV	200°C	8
Fine Silver (Ag)	Highest conductivity, allows current to burst through surface films	Low melting temperature, forms sulfides	cladding plating PVD	> 75 g	75 - 200 HV	125°C	103
Coin Silver (90 Ag, 10 Cu)	Better wear resistance than fine Ag, high conductivity	Low melting temperature, forms sulfides and oxides, intermetallics	cladding	> 75 g	65 - 100 HV	125°C	86
Platinum (Pt)	High hardness and wear resistance. Forms no oxides or sulfides.	Catalyst - forms organic films, intermetallics	cladding plating	> 50 g	200 - 400 HV	200°C	21
Nickel (Ni)	Usually used as an underplating, prevents migration of corrosion products, passivates pores	Forms oxides, brittle or high stress coatings may reduce fatigue life If used alone, vulnerable to fretting corrosion	electroplating electroless cladding PVD	> 300 g if used alone	150 - 700 HV depending on process and thickness	125°C	18
Aluminum (Al)	Wire bonding to Al wires	Readily forms oxides, forms brittle intermetallic with Cu	cladding PVD hot dipping	Permanent Connection	70 - 90 HV	125°C	60
Tin (Sn)	Low cost, easily solderable Can be used for high voltage, high current non-switching applications	Oxides, intermetallics, whiskers, fretting corrosion	electroplating hot dipping cladding	> 100 grams	~ 30 HV	150°C for some automotive applications	14
Tin Lead Solders	Easily solderable, cheap protective coating/lubricant Thick solders allow strong bonds, melt readily in fuses	Soft, requires clean surfaces and fluxes for bonding Not wear resistant Not RoHS-Compliant	electroplating hot dipping reflowing cladding	Permanent Connection	~ 25 HV	60°C	11-12 for eutectic SnPb
Silver Tin Copper SnAgCu or SAC Solders	Pb-free, RoHS-compliant alternative to tin lead solders	Melt and reflow at higher temperatures than leaded solders. May lead to warpage/cracking on PCB or components.	electroplating hot dipping reflowing cladding	Permanent Connection	~ 30 HV	60°C	1300%

Materion Brush Performance Alloys

6070 Parkland Boulevard
Mayfield Heights, OH 44114 USA
phone: 216.486.4200 fax: 216.383.4005
e: BrushAlloys-Info@Materion.com

TECHNICAL INQUIRIES

ph: 800.375.4205

MATERION CORPORATION

www.materion.com

AT0017/0311

©2011 Materion Brush Inc.